

## Low Cost Triggered Spark Gap (TSG-LC-001)



### Key Points

- Low Cost
- Rugged Ceramic-Metal Construction
- Low Capacitance

The **Low Cost Triggered Spark Gap** provides a cost effective, high current, low impedance switch. The **Low Cost Triggered Spark Gap** is significantly lower in cost than standard triggered spark gaps ideally suited for low repetition applications. The compact modular design and its low cost provides a triggered solution for traditional over-voltage spark gap applications.

### Operating Specifications

Operating Voltage	1 kV to 2.5 kV
Maximum Current	5 kA
Static Breakdown Voltage	$\geq 3.5$ kV
Trigger Supply Voltage	200-300 VDC
Trigger Pulse	7VDC to 20VDC @ 100mA minimum
Operating Temperature Range	-40°C to +71°C
Operations	<10
Trigger Delay	TBD
Capacitance	<1.5 pF

### Physical Specifications

Module Size	2.00" x 2.00" x 1.00" (L x W x H)
Mounting	Surface mount pads

**Test Data**  
 Capacitor 1uF, Voltage 2.5kV  
 Trigger Voltage: 290 VDC

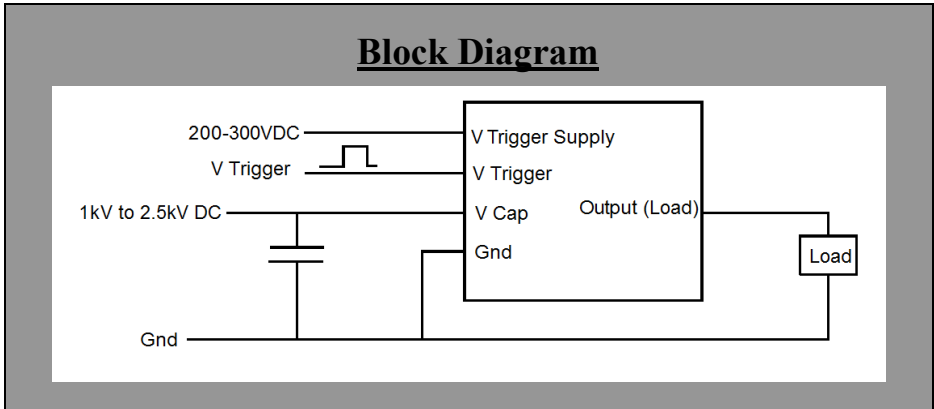
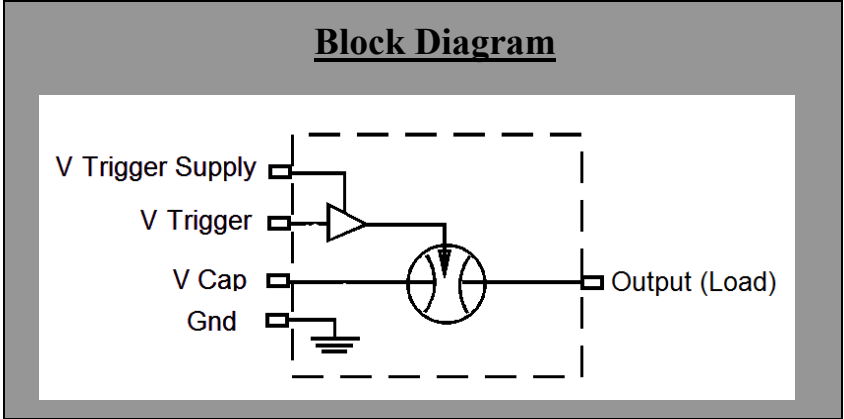
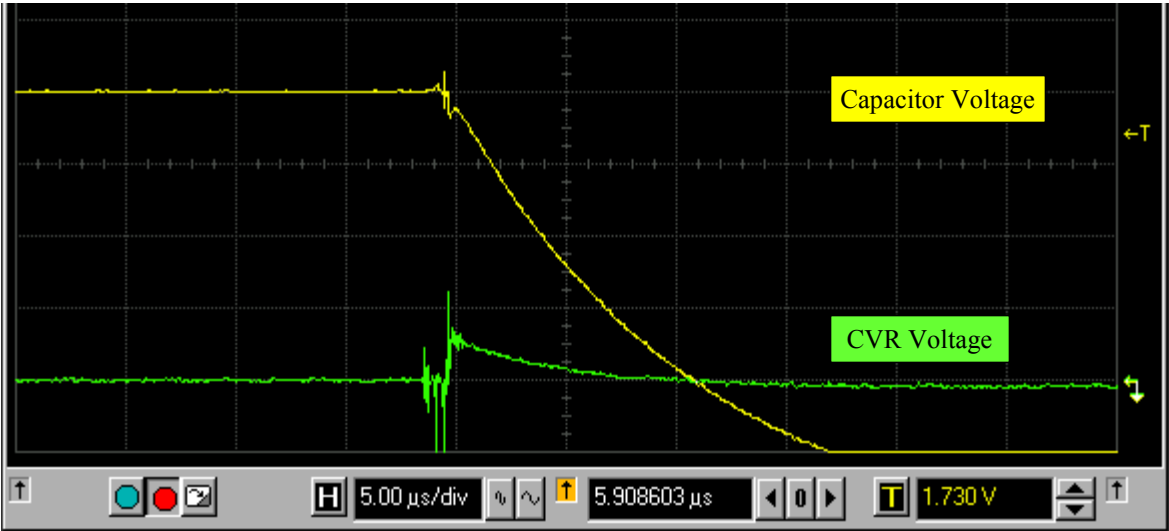

# Mechanicals

